

Vectron Space and High-Reliability Frequency-Control Solutions

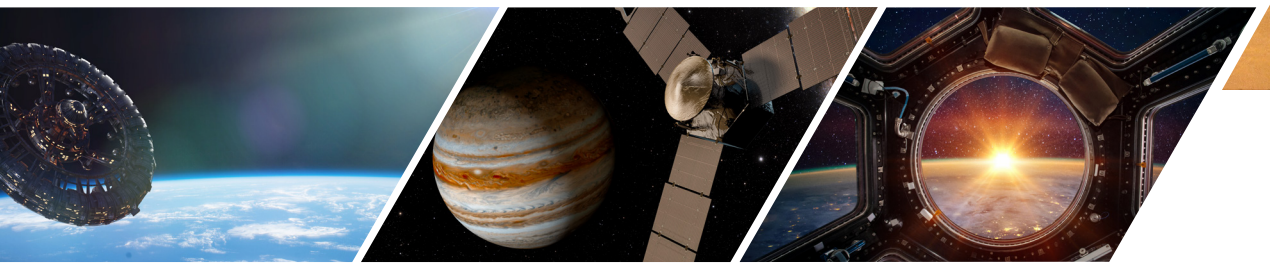



Extensive Space Heritage

Microchip's Vectron state-of-the-art crystal manufacturing facility in Mt. Holly Springs, PA employs some of the most experienced frequency control personnel in the industry. Today, we draw on the expertise of these individuals to supply precision quartz crystals and blanks to our military, space, defense and commercial customers, utilizing state-of-the-art design, manufacturing and control systems to meet and exceed customer expectations for reliability, performance and value. Vectron brand oscillators, consist of products from several acquisitions, including Vectron International, McCoy Electronics and Oak Frequency Control.

When the world celebrated the 50th anniversary of the Apollo 11 moon landing in 2019, it was due in part to the McCoy Electronics frequency control products that were onboard the lander. Prior to the Apollo program, our products were onboard the United States' first successful space exploration mission in 1958.

Solutions From Low Earth Orbit to Interstellar Space

For over six decades, Vectron's products have flown in hundreds of missions. Our products are currently in low earth orbit, geosynchronous orbit and on the Moon, Mars and Venus. Voyager 1, the furthest man made object from the earth, has frequency control products that have operated continuously for 42 years, and are aiding in the transmission of data from interstellar space, a distance of 13 billion miles. The following chart highlights some of the major programs that have used Vectron oscillators.

Continuous Innovation

With over six decades of proven flight heritage, we draw on our experience and continue to innovate, providing state of the art designs, world class manufacturing and unparalleled customer service to assist your space mission success now and into the future.

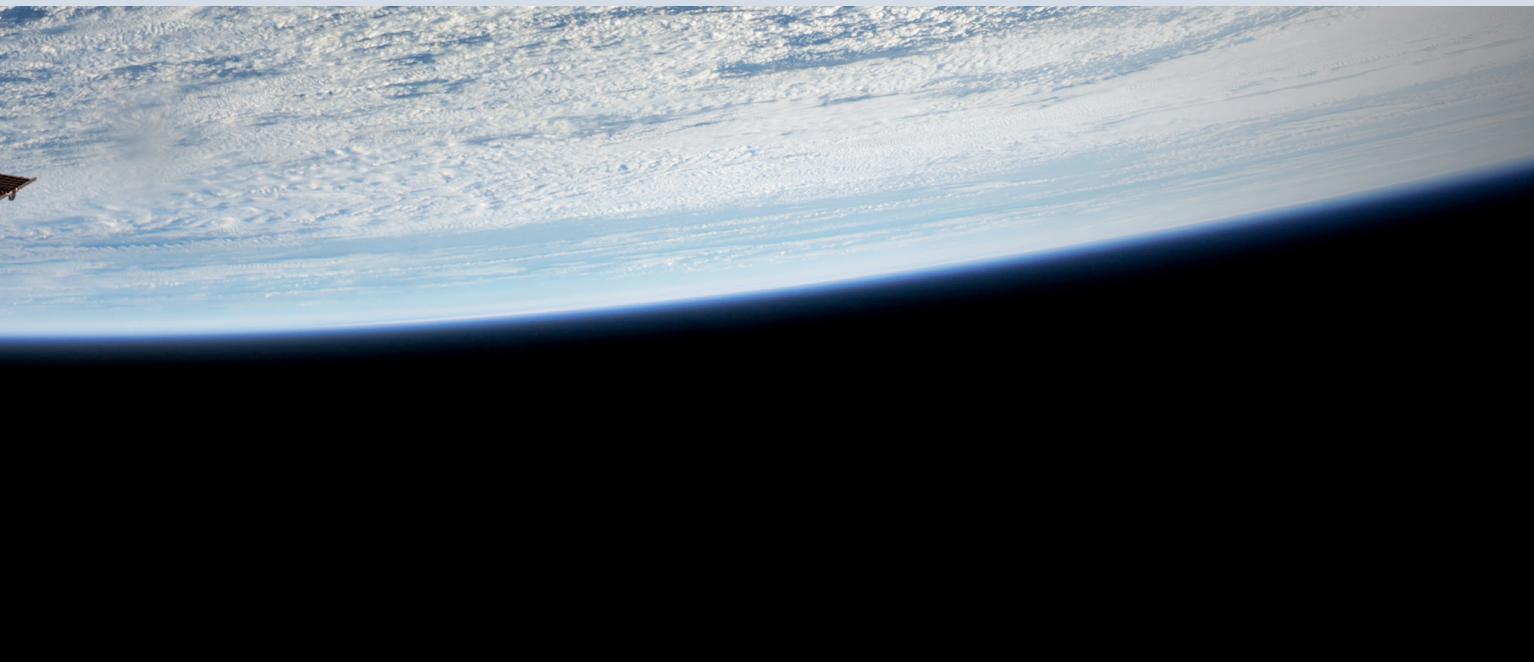

Highlights of Major Programs Using Vectron Oscillators

1960s	Apollo	Gemini	Pioneer	Intelsat
1970s	GPS	Viking	Nimbus	Voyager
1980s	Galileo	Milstar	Magellan	Space Shuttle
1990s	Centaur	Cassini-Huygens	Hubble Telescope	International Space Station
2000s	Mars Spirit	Mars Odyssey	New Horizons	Global Star II
2010s	Orion	GPS III	Galileo	Atlas IV launch vehicle

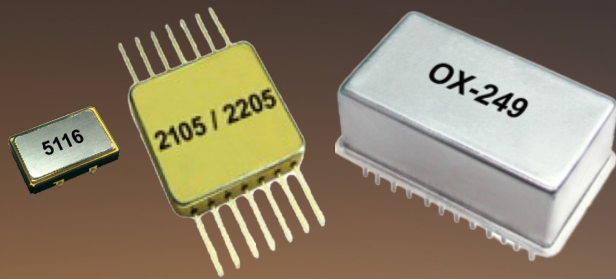

AS-9100 Certified Facilities

Our space and military hybrid manufacturing and test facilities are segregated from our commercial product areas with their own engineering, management and quality personnel providing a focused approach to giving our customers the best in quality and on-time deliveries.

Our people are our most valuable asset and production, engineering and management personnel provide us with experience unparalleled in our industry. Our most experienced production people are assigned to the space product lines providing a top quality product.

We have two Class 100,000 clean rooms totaling 9,350 sq ft for our hybrid production which are maintained to Class 10,000 and the many additional Class 100 Laminar Flow work centers provide us with the right environment to build products second to none in our industry. Given our clean room area with state-of-the-art manufacturing equipment and the industry's best people, we have a facility we are proud to show off to our many visitors.

Space Qualified Frequency Control Products

Vectron crystal oscillators are carefully designed to handle the challenges of exo-atmospheric flights. Products are ruggedized to operate and survive the launch environments, and withstand radiation effects presented by low earth orbit to deep space exploration. Other non-crystal based products round out Microchip's space frequency-control products.

- Crystals
- Crystal Oscillators (XO)
- Temperature Compensated Crystal Oscillators (TCXO)
- Voltage Controlled Crystal Oscillators (VCXO)
- Voltage Controlled SAW Oscillators (VCSO)
- Oven Controlled Crystal Oscillators (OCXO)
- Evacuated Miniature Crystal Oscillators (EMXO)
- SAW filters
- Atomic Clocks



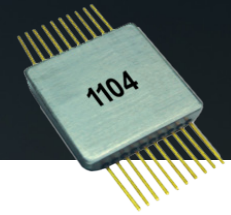

Leading-Edge Solutions for Space

Catalog Specifications for Space

Starting in 1958 and continuing for nearly 40 years, we were the recipient of your space oscillator Source Control Drawings (SCD).

In the late 1990s, the tables were turned when we created the OS-68338, a specification for high reliability clocks that allowed our customers to choose from common screening tests, component pedigrees and design analyses.

Today, Microchip's Vectron portfolio has seventeen high-reliability specifications. Please visit our website for a complete list of specifications.

Advantages of Microchip's Vectron Catalog Specifications Include:

- No OEM SCD or custom part numbers required
- Ordering codes define EEE pedigree and QA level
- MIL-PRF-55310/38534 equivalent screening options
- Clearly defines radiation tolerance of active devices
- Multiple package, output and supply voltage options
- No additional platform qualification required
- Shorter leadtimes and lower overall cost
- Promotes design efficiencies (BOM creation and entry)
- Enables standard build/screen/test documentation
- Encourages hi-rel process consistency
- Procurement and manufacturing economies of scale
- Revisions posted "real-time" to Vectron website
- Quick design-in capability utilizing overage
- Design flight heritage

REV	DESCRIPTION	DATE	PREP	APPD
O	CO-29999	4/2/19	SM	LT/DF

OS-68338 Hi-Rel Clock Oscillator Series

EXAMPLES SHOWN IN ACTUAL SIZE

		Oscillator Specification, Hybrid Clock Hi-Rel Standard		
MOUNT HOLLY SPRINGS, PA 17065 <small>THE RECORD OF APPROVAL FOR THIS DOCUMENT IS MAINTAINED ELECTRONICALLY WITHIN THE ERP SYSTEM</small>		CODE IDENT NO 00136	SIZE A	DWG. NO. OS-68338
		UNSPECIFIED TOLERANCES: N/A	REV O	
		SHEET 1 OF 35		



Part Numbering Convention

A part number, including screening levels and component pedigree, can be directly configured from the specifications. While each catalog has slightly different part numbering options, the below example from OS-68338 provides a general overview.

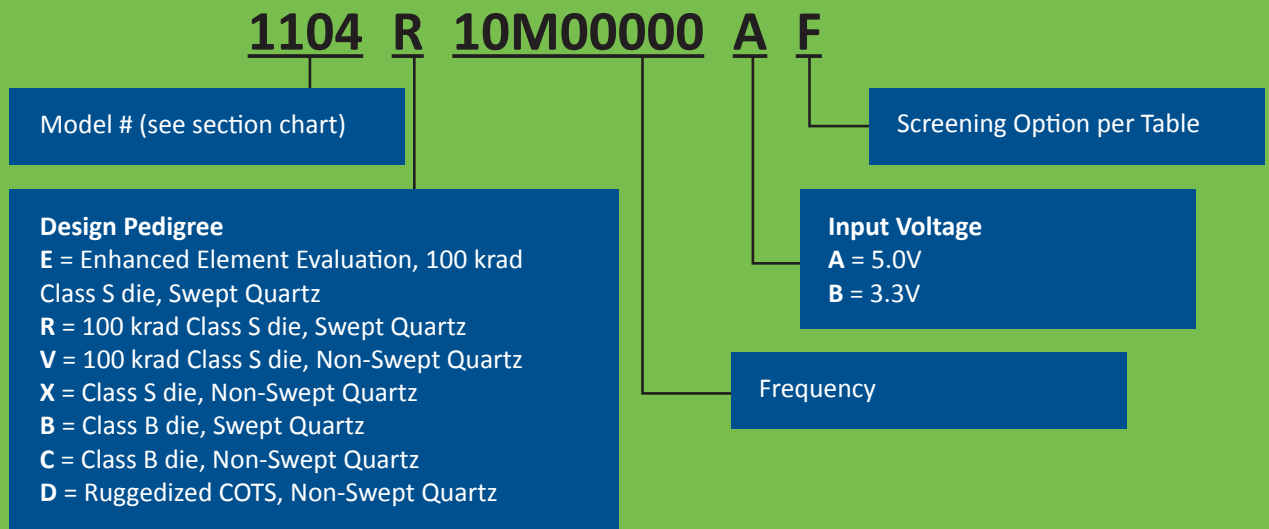



Component Pedigree

Microchip can tailor the component pedigree of the Vectron high-reliability oscillators to ensure program cost and leadtime requirements are met. Various combinations and options are included in most specifications. Please refer to the individual product specification for ordering options. These options include:

- Swept vs. Non Swept Quartz
- Enhanced Element Evaluation
- 300 krad, 100 krad or untested wafer lots
- Class S, B or Ruggedized COTS components

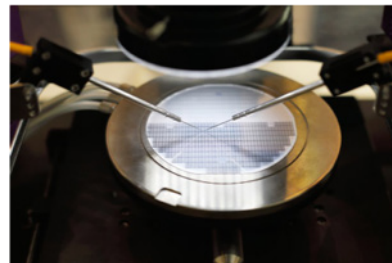
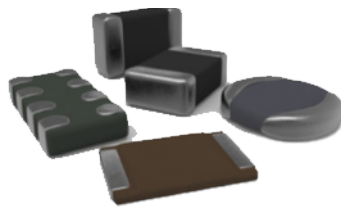

Screening and Testing Options

Vectron oscillators are available with predefined screening options based upon MIL-PRF-38534 and MIL-PRF-55310, as well as Engineering Model (EM) option. The screening options include common test methods such as non-destruct bond pull, burn-in, thermal shock, fine and gross leak and PIND testing. Screening options vary slightly by specification.

Please visit our website to review the appropriate catalog specification.

- MIL-PRF-38534 Class K Screening
- Modified MIL-PRF-55310 Class B Screening & Group A QCI
- Modified MIL-PRF-55310 (Rev E) Class S Screening & Group A QCI
- Modified MIL-PRF-38534 Class K Screening, Group A QCI & 30-day Aging
- MIL-PRF-55310 Class B Screening & Groups A & B QCI
- MIL-PRF-55310 (Rev E) Class S Screening & Groups A & B QCI
- Modified MIL-PRF-55310 Class B Screening & Post BI Electrical
- MIL-PRF-55310 (Rev F) Class S Screening & Groups A & B QCI
- Engineering Model (EM)



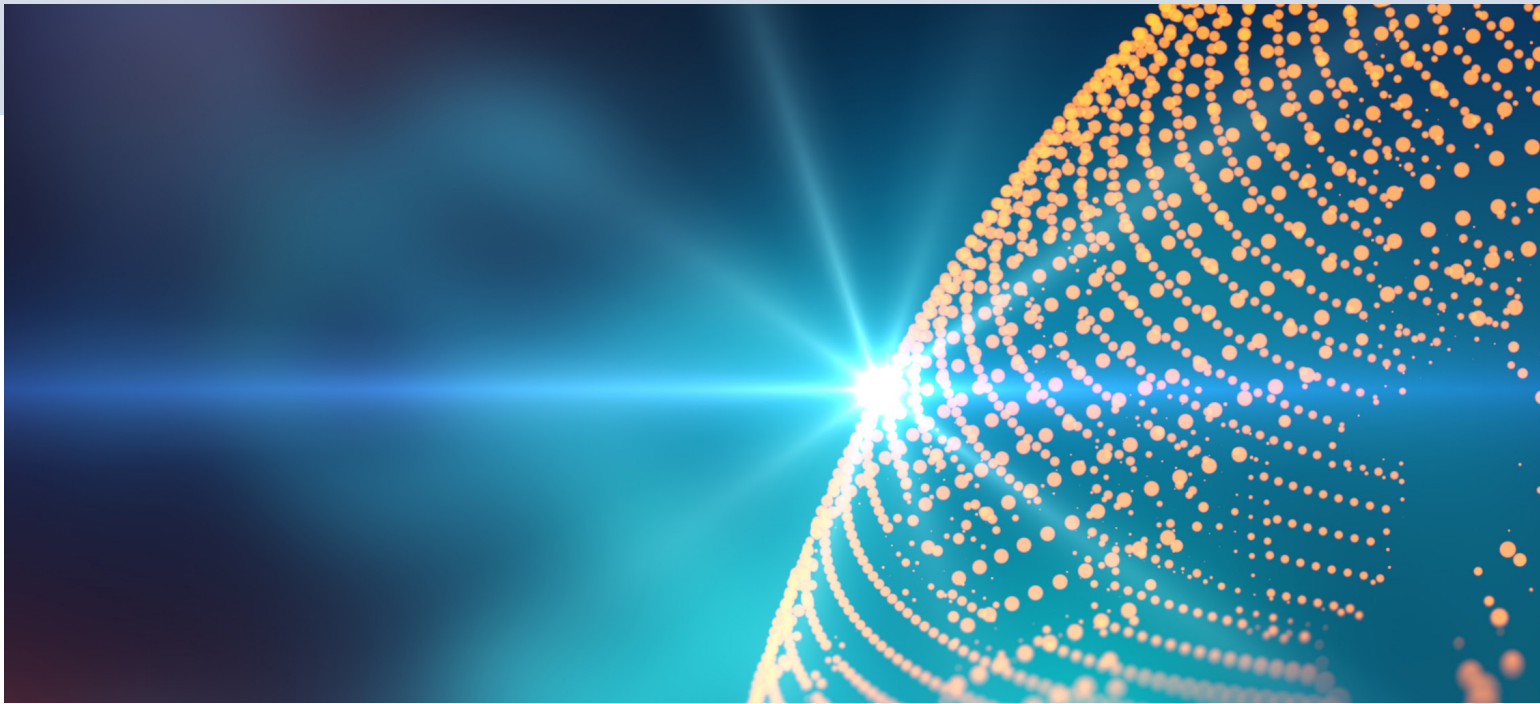

Test Capabilities

Our test and environmental laboratories enable us to offer you a broad range of device screening and qualification options. The primary test methods we use are defined in MIL-STD-202 and MIL-STD-883. For tests we are unable to conduct in-house, we subcontract to AS9100 certified test facilities. The below is a partial list of our capabilities.

In House			
Aging	g-Sensitivity	Mechanical Shock	Barometric Pressure
Humidity	RealTime X-Ray	Die Shear Testing	Frequency Slew Test
Phase Noise	Thermal Vacuum	Terminal Strength	Constant Acceleration
Life Testing	Salt Atmosphere	Fine Leak - Helium	Wirebond Pull Testing
Thermal Shock	Allan Deviation	Temperature Cycling	Band Width Modulation
Sine Vibration	Random Vibration	Moisture Resistance	Solderability/ Steam Age
Magnetic Field Sensitivity		Particle Impact Noise Detection (PIND)	
Resistance to Soldering Heat		X-ray Fluorescence (Pure Tin termination Detection)	
Outside Testing			
Pyrotechnic Shock		ElectroMagnetic Interference	
Fine/Gross Leak - Krypton		Class S/K Element Evaluation	
Residual Gas Analysis (RGA)		Destructive Part Analysis (DPA)	
TID/ELDRS	Single Event Effects	Neutron Fluence	Prompt Dose



Additional Design, Assembly, Test and Inspection Options

In addition to the options called out by the screening and component pedigree codes, additional testing, services, design and assembly options are available. These may require either an additional line on a purchase order or a customized part number. An example of additional options are listed below. Please contact Microchip if you have another requirement.

Program Management	Failure Mode and Effect Analysis (FMEA)
Customer Defined SDRL	Process Identification Documentation (PID)
Component Traceability	Mean Time Between Failure Calculation (MTBF)
Long Term Aging Predictions	Custom Qualification Test Procedure and Review
Design Reviews (PDR/MRR/CDR)	Source Inspections (Pre Cap, Final, Government)
Worst Case Circuit Analysis (WCCA)	Part Stress and Derating Analysis
Custom Acceptance Test Procedure Generation and Review	

Full Customization and Build-to-Print Options

For programs with unique requirements that are not addressed by our catalog specifications, Microchip will work closely with you to develop a custom device or develop a compliance matrix to your Source Control Drawing (SCD). Microchip can develop unique packages per your drawings and is capable of meeting a broad range of custom requirements.

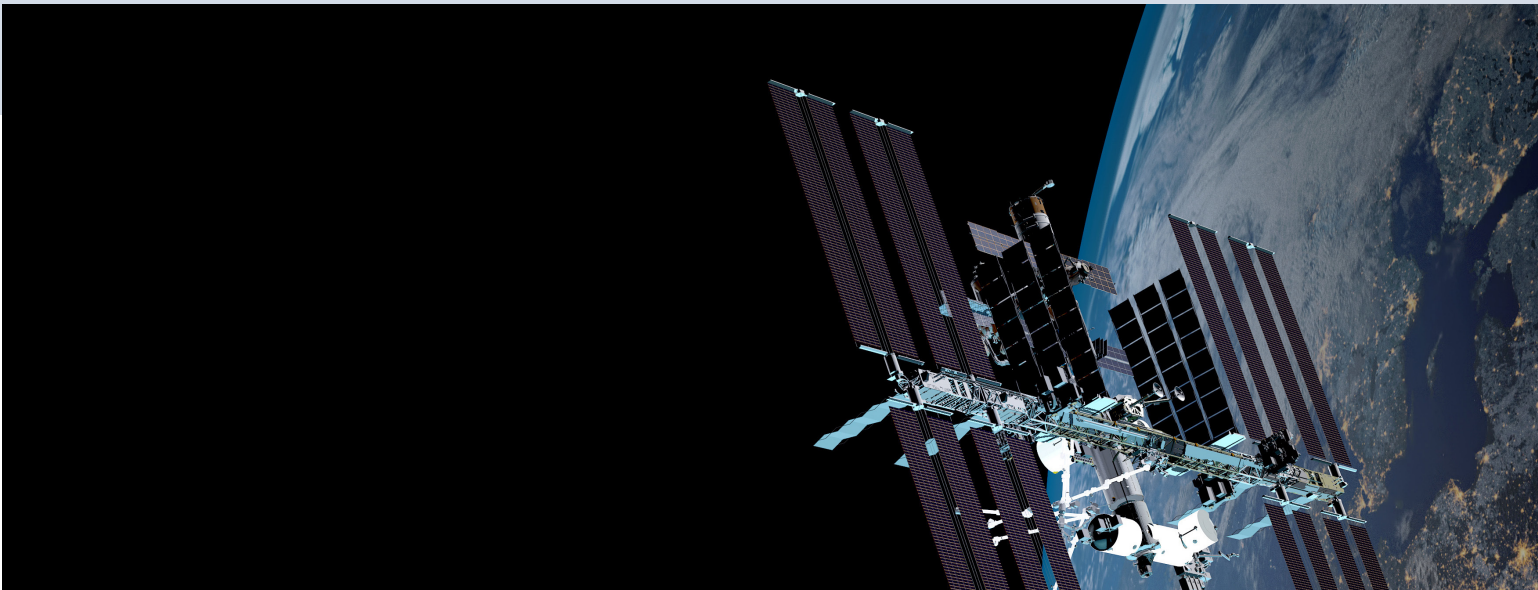

Single-Ended Clock Oscillator (XO)

Full specifications are available that define the design, assembly and functional evaluation for a wide variety of TTL, CMOS and Sine XOs for various configurations. We invite you to download these from our website.

- 8 package choices
- Lead forming options
- ± 15 ppm frequency accuracy at 25°C
- ± 50 ppm temperature stability
-55°C to +125°C
- CMOS, TTL and Sine options
- 300 krad TID options
- 120 MeV-cm²/mg SEL options
- 90 MeV-cm²/mg SET options

OS-68338

- CMOS and TTL clocks
- Output frequencies to 100 MHz
- 8 different package sizes including
5 × 7 mm

DOC204900

- High frequency CMOS clock
- Output frequencies to 160 MHz
- 2.5V supply option

DOC206379

- CMOS clock for deep space
applications
- Output frequencies to 100 MHz
- 300 krad total ionizing dose

DOC207975

- High frequency Sinewave clock
- Output frequencies to 500 MHz
- 300 krad Total Ionizing Dose

M55310/16S

- DSCC MIL-PRF-55310 QPL oscillator
- S Level screening
- 375 kHz to 80 MHz

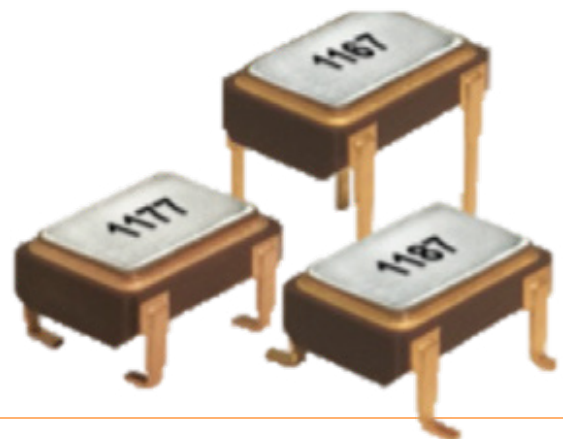



Leading-Edge Solutions for Space

Specification	Model Number	Lead Form Version	Output Logic	Number of RF outputs	Frequency Range (MHz)	Radiation Tolerance			Package	Dimensions (mm)
						TID	SET	SEL		
						kRad	MeV-cm ² /mg	MeV-cm ² /mg		
OS-68338	1101	1121	CMOS	1	0.35 to 100	100	40	120	12-Lead Flatpack	16.5 × 16.5 × 3.5
	1102	1122	CMOS	1	0.35 to 100	100	40	120	14-Lead Flatpack	20.3 × 15.2 × 3.5
	1103	1119	CMOS	1	0.35 to 100	100	40	120	16-Lead Flatpack	12.7 × 9.6 × 3
	1104	1120	CMOS	1	0.35 to 100	100	40	120	20-Lead Flatpack	16.5 × 16.5 × 3.8
	1105		CMOS	1	0.35 to 100	100	40	120	14-pin DIP	22.8 × 13.7 × 5.1
	1107		TTL	1	0.35 to 100	100	40	120	12-Lead Flatpack	16.5 × 16.5 × 3.5
	1108		TTL	1	0.35 to 100	100	40	120	14-Lead Flatpack	20.3 × 15.2 × 3.5
	1109		TTL	1	0.35 to 100	100	40	120	16-Lead Flatpack	12.7 × 9.6 × 3
	1110		TTL	1	0.35 to 100	100	40	120	20-Lead Flatpack	16.5 × 16.5 × 3.8
	1111		TTL	1	0.35 to 100	100	40	120	14-pin DIP	22.8 × 13.7 × 5.1
	1115		CMOS	1	0.35 to 100	100	40	120	4-pin 1/2 DIP	12.7 × 12.75.08
	1116		CMOS	1	0.35 to 100	100	40	120	4 J-Lead SMT	14.0 × 8.9 × 4.8
	1117		TTL	1	0.35 to 100	100	40	120	4 J-Lead SMT	14.0 × 8.9 × 4.8
	1157		CMOS	1	1.5 to 100	100	40	120	4 Pad LCC	7 × 5 × 2
	1167	1177/1187	CMOS	1	1.5 to 100	100	40	120	4-Lead Ceramic DIP	7 × 5 × 2
DOC204900	1403	1419	CMOS	1	12 to 160	100	90	90	16-Lead Flatpack	12.7 × 9.6 × 3
	1404	1420	CMOS	1	12 to 160	100	90	90	20-Lead Flatpack	16.5 × 16.5 × 3.8
DOC206379	1504	1520	CMOS	1	12 to 100	300	93	93	20-Lead Flatpack	16.5 × 16.5 × 3.8
DOC207975	1704	1720	SINE	1	10 to 200	300	N/A	N/A	20-Lead Flatpack	16.5 × 16.5 × 3.8
	1719	1721	SINE	1	200 to 500	300	N/A	N/A	16-Lead Flatpack	25.4 × 25.4 × 3.8
MIL-PRF-55310	M55310/16S		TTL	1	.375 to 80	100	40	120	14-pin DIP	22.8 × 13.7 × 5.1



Differential High Reliability XOs

For higher frequency and longer trace lengths, differential XOs are designed to maintain signal integrity. Available in both LVDS and LVPECL, and built in fan out buffers.

- 3 package choices
- Lead forming options
- ±15 ppm frequency accuracy at 25°C
- ±50 ppm temperature stability -55°C to +125°C
- LVPECL and LVDS options
- 300 krad TID options
- 120 MeV-cm2/mg SEL options
- 84 MeV-cm2/mg SET options

DOC203679

- LVDS clock
- Single, dual or quad differential pairs
- Output frequencies to 200 MHz

DOC206903

- LVDS clock for deep space applications
- Output frequencies to 200 MHz
- 300 krad total ionizing dose

DOC203810

- High frequency LVPECL clock
- Output frequencies to 700 MHz
- 50 krad ELDRs

OS-68338 CMOS Clock 1157	OS-68338 CMOS Clock 1167	OS-68338 CMOS Clock 1177	OS-68338 CMOS Clock 1187
OS-68338 CMOS/TTL Clock 1101/1107/1121	OS-68338 CMOS/TTL Clock 1102/1108/1122	OS-68338 CMOS/TTL Clock 1103/1109/1119	OS-68338 CMOS/TTL Clock 1104/1110/1120
OS-68338 CMOS Clock 1115	OS-68338 CMOS/TTL Clock 1105/1111 MIL-PRF-55310/165	OS-68338 CMOS/TTL Clock 1116/1117	DOC203679 LVDS Clock 1204/1220/1208/1240/1216/1280
			DOC203810 LVPECL Clock 1304/1320/1308/1340
			DOC204900 CMOS Clock 1403/1419
			DOC204900 CMOS Clock 1404/1420
			DOC206379 300krad CMOS Clock 1504/1520
			DOC206903 300krad LVDS Clock 1604/1620/1608/1640/1616/1680

MICROCHIP Space Qualified, Crystal Controlled, Hybrid Clock Oscillators



Leading-Edge Solutions for Space

Specification	Model Number	Lead Form Version	Output Logic	Number of RF outputs	Frequency Range (MHz)	Radiation Tolerance			Package	Dimensions (mm)
						TID	SET	SEL		
						kRad	MeV-cm ² /mg	MeV-cm ² /mg		
DOC203679	1203	1219	LVDS	1 pair	50 to 200	300	67	120	16-Lead Flatpack	12.7 × 9.6 × 3
	1204	1220	LVDS	1 pair	12 to 200	100	84.96	100	20-Lead Flatpack	16.5 × 16.5 × 3.8
	1208	1240	LVDS	2 pairs	12 to 200	100	84.96	100	20-Lead Flatpack	16.5 × 16.5 × 3.8
	1216	1280	LVDS	4 pairs	12 to 200	300	67	120	20-Lead Flatpack	16.5 × 16.5 × 3.8
DOC203810	1304	1320	LVPECL	1 pair	100 to 200	50 (ELDRS)	-	-	20-Lead Flatpack	16.5 × 16.5 × 3.8
	1308	1340	LVPECL	2 pairs	100 to 200	50 (ELDRS)	-	-	20-Lead Flatpack	16.5 × 16.5 × 3.8
	1319	1321	LVPECL	1 pair	200 to 700	50 (ELDRS)	-	-	16-Lead Flatpack	25.4 × 25.4 × 3.8
DOC206903	1604	1620	LVDS	1 pair	12 to 200	300	67	120	20-Lead Flatpack	16.5 × 16.5 × 3.8
	1608	1640	LVDS	2 pairs	12 to 200	300	67	120	20-Lead Flatpack	16.5 × 16.5 × 3.8
	1616	1680	LVDS	4 pairs	12 to 200	300	67	120	20-Lead Flatpack	16.5 × 16.5 × 3.8



RTG4 SERDES Reference Clocks

Microchip's Vectron High-Reliability Space Clock Oscillators are the only oscillators fully characterized for use as the SERDES reference clocks for the Microchip RTG4 radiation-hardened FPGA. Please visit the Microchip website to download the application note AN3216.

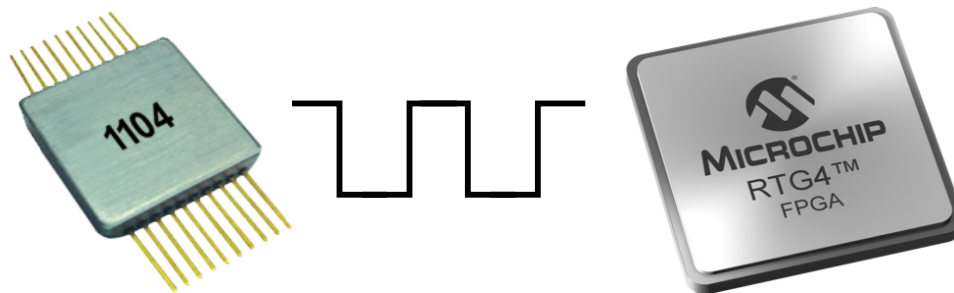

Signal Type	RTG4 Reference Clock Input	Clock Type	Vectron Brand Clock	Radation Tolerance (krad)	Supply Voltage (V)	Maximum Frequency (MHz)
Differential	LVDS25_ODT	LVDS	DOC203679	100	3.3	200
			DOC206903	300	3.3	
	LVDS25_ODT	LVPECL	DOC203810	50 (ELDRS)	3.3	700
	LVDS25	LVDS	DOC203679	100	3.3	200
			DOC206903	300	3.3	
	LVDS33	Do Not Use				
LVPECL33	Do Not Use					
Single Ended	LVCMOS33	CMOS	OS-68338	100	3.3	100
			DOC204900	100	3.3	160
			DOC206379	300	3.3	100
	LVCMOS25		DOC204900	100	2.5	160



Precision Crystals

In addition to oscillators, Microchip provides sealed crystal resonators specifically designed for space applications. Crystals are plated in a Class 100 environment and sealed in a fully integrated cold weld vacuum seal system.

- Microchip patented QRM design
- g-Sensitivity down to $1E-10/g$
- Swept quartz for space applications
- 100% phase noise screening options
- Active or passive pre-aging
- Multiple packaging options in industry standard footprints
- Frequencies up to 225 MHz
- MIL-PRF-3098 and ESA-3501 equivalents



SAW Filters

Microchip offers SAW filters for space and high reliability applications. Most SAW filters are custom designed for customer applications, but many of our standard filters can also be built and screened for space requirements.

- Frequency range 30 MHz to 2.7 GHz
- Low loss, loss reduced and precision high loss filters available
- Shape factors as low as 1.03
- Through hole, connectorized and SMD packaging
- Hermetic sealing options
- Butterworth, Chebyshev, Reactance Filters and various FIR and IIR types

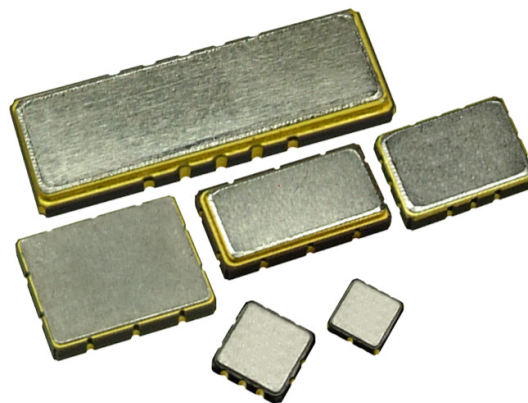



High-Reliability Temperature-Compensated Crystal Oscillators (TCXO)

Microchip’s Vectron Space TCXOs provide temperature stabilities as tight as ± 0.5 ppm with 100 krad TID performance. Options include multiple package configurations, (including the world’s smallest space qualified TCXO), a variety of temperature stability and ranges, multiple screening options and a proven flight history. Microchip’s two general specifications, DOC200103 and DOC207139, provide engineers with a fast path to mission success.

- 5 package choices
- Lead forming options
- 4-point mount crystals
- CMOS, LVDS and Sine options
- Multiple supply voltage options
- 300 krad total ionizing dose options

DOC200103

- CMOS and Sine TCXOs
- Output frequencies to 500 MHz
- 5 different package configurations

DOC207139

- LVDS TCXOs
- Output frequencies to 200 MHz
- Single or Dual Pair complimentary outputs

DOC200103 CMOS/SINE TCXO
2101
2111

DOC200103 CMOS/SINE TCXO
2102/2202
2112/2212

DOC200103 CMOS/SINE TCXO
2103/2203
2113/2213

DOC207139 LVDS TCXO
2123/2223
2133/2233

DOC200103 CMOS/SINE TCXO
2104/2204
2114/2214

DOC200103 CMOS/SINE TCXO
2105/2205
2115/2215

MICROCHIP

Space Qualified, Temperature Compensated, Crystal Oscillators

Operating Temperature Range (°C)	Frequency Stability (ppm)
0 to 50	± 0.5
0 to 50	± 1
0 to 70	± 1
0 to 70	± 2
0 to 70	± 5
-20 to +70	± 1
-20 to +70	± 2
-20 to +70	± 5
--40 to +85	± 2
-40 to +85	± 4
-40 to +85	± 5
-55 to +105	± 10



Specification	Model Number	Lead Form Version	Output Logic	Number of RF outputs	Frequency Range (MHz)	Radiation Tolerance			Package	Dimensions (mm)
						TID	SET	SEL		
						kRad	MeV-cm ² /mg	MeV-cm ² /mg		
DOC200103	2101		CMOS	1	.3 to 100	100	40	120	24-pin DDIP	35.3 × 20.7 × 10.8
	2102	2202	CMOS	1	.3 to 100	100	40	120	32 Lead Flatpack	25.4 × 25.4 × 5.1
	2103	2203	CMOS	1	.3 to 100	100	40	120	24 Lead Flatpack	35.6 × 25.9 × 7.6
	2104	2204	CMOS	1	.3 to 100	100	40	120	14 Lead Flatpack	20.0 × 20.0 × 12.7
	2105	2205	CMOS	1	.3 to 100	100	40	120	14 Lead Flatpack	19.5 × 19.5 × 6.6
	2111		Sine	1	10 to 225	100	N/A	N/A	24-pin DDIP	35.3 × 20.7 × 10.8
	2112	2212	Sine	1	10 to 150	100	N/A	N/A	32 Lead Flatpack	25.4 × 25.4 × 5.1
	2113	2213	Sine	1	10 to 500	100	N/A	N/A	24 Lead Flatpack	35.6 × 25.9 × 7.6
	2114	2214	Sine	1	10 to 150	100	N/A	N/A	14 Lead Flatpack	20.0 × 20.0 × 12.7
	2115	2215	Sine	1	10 to 150	100	N/A	N/A	14 Lead Flatpack	19.5 × 19.5 × 6.6
DOC207139	2123	2222	LVDS	1 pair	12 to 200	300	67	120	24 Lead Flatpack	35.6 × 25.9 × 7.6
	2133	2233	LVDS	1 pair	12 to 200	300	67	120	24 Lead Flatpack	35.6 × 25.9 × 7.6



High Reliability Voltage Controlled Crystal Oscillators (VCXO)

Vectron VCXOs are crystal based frequency tunable oscillators. VCXOs are ideal for phase-locked loop or frequency modulation applications.

High Reliability Voltage Controlled SAW Oscillators (VCSO)

VCSOs extend the upper frequency range of Vectron's tunable oscillator offering to 1.5 GHz with a -165 dBc/Hz noise floor and no subharmonics.

- 8 package choices
- Lead forming options
- CMOS, LVDS, LVPECL and Sine options
- Absolute pull range 20 ppm minimum

DOC204898

- LVPECL output VCXO
- Output frequencies to 700 MHz

DOC206218

- CMOS output VCXO
- Output frequencies to 100 MHz

DOC206906

- LVPECL VCSO
- Output frequencies to 1000 MHz

DOC204899

- LVDS output VCXO
- Output frequencies to 200 MHz

DOC206559

- Sine output VCSO
- Output frequencies to 1500 MHz
- 300 krad Total Ionizing Dose

DOC207753

- CMOS or Sine outputs VCXO
- Output frequency to 675 MHz

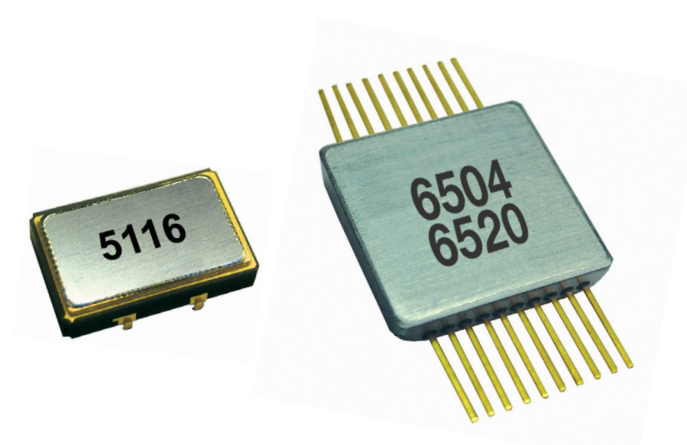

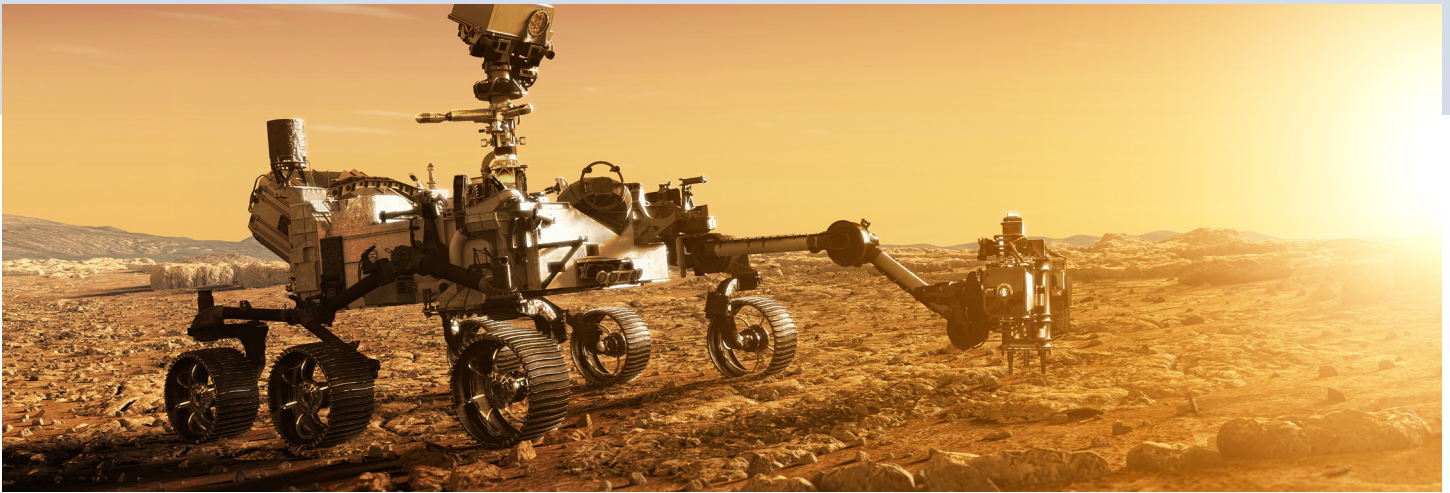

Specification	Model Number	Lead Formed Version	Oscillator Type	Output Logic	Frequency Range (MHz)	Absolute Pull Range (ppm)	Package	Dimensions (mm)
DOC204898	5319	5321	VCXO	LVPECL	25 to 700	20	16-lead flatpack	25.4 × 25.4 × 3.8
DOC204899	5219	5221	VCXO	LVDS	25 to 200	20	16-lead flatpack	25.4 × 25.4 × 3.8
DOC206218	5116		VCXO	CMOS	1 to 100	50/30	4 J-Lead SMT	14.0 × 8.9 × 4.8
DOC206559	6504	6520	VCXO	Sine	300 to 1500	20	20-lead flatpack	16.5 × 16.5 × 3.8
DOC206906	6304	6320	VCXO	LVPECL	300 to 1000	20	20-lead flatpack	16.5 × 16.5 × 3.8
DOC207753	5101		VCXO	CMOS	.3 to 100	20	24-pin DDIP	35.3 × 20.7 × 10.8
	5102	5202	VCXO	CMOS	.3 to 100	20	32-Lead Flatpack	25.4 × 25.4 × 5.1
	5103	5203	VCXO	CMOS	.3 to 100	20	24-Lead Flatpack	35.6 × 25.9 × 7.6
	5104	5204	VCXO	CMOS	.3 to 100	20	14-Lead Flatpack	20.0 × 20.0 × 12.7
	5105	5205	VCXO	CMOS	.3 to 100	20	14-Lead Flatpack	19.5 × 19.5 × 6.6
	5111		VCXO	Sine	10 to 300	20	24-pin DDIP	35.3 × 20.7 × 10.8
	5112	5212	VCXO	Sine	10 to 150	20	32-Lead Flatpack	25.4 × 25.4 × 5.1
	5113	5213	VCXO	Sine	10 to 675	20	24-Lead Flatpack	35.6 × 25.9 × 7.6
	5114	5214	VCXO	Sine	10 to 150	20	14-Lead Flatpack	20.0 × 20.0 × 12.7
	5115	5215	VCXO	Sine	10 to 150	20	14-Lead Flatpack	19.5 × 19.5 × 6.6



High Stability Space Frequency References

For temperature stabilities better than 500 ppb, Vectron brand oscillators and other Microchip products provide multiple solutions depending on size, power, radiation and stability requirements.

Oven Controlled Crystal Oscillator (OCXO)

OCXOs are oscillators combined with an oven maintaining the crystal unit at a precise temperature over the operating temperature range. The OCXO is the most accurate of all crystal oscillators.

Evacuated Miniaturized Crystal Oscillator (EMXO)

An EMXO is a unique miniaturized oven controlled oscillator in an evacuated cavity. This design provides a small physical size, low profile, low-power consumption, fast warm-up and tight temperature stabilities

Space Chip Scale Atomic Clock (CSAC)

The space CSAC is a low power cesium atomic clock that has been qualified for low earth orbit applications, capable of achieving sub 1 ppb temperature stabilities.

- Stability options to ± 0.3 ppb
- Power options as low as 120 mW
- Radiation tolerance up to 300 krad
- Screening options available





OX-249

- Output frequencies to 100 MHz
- 300 krad total ionizing dose

EX-219

- Output frequencies to 120 MHz
- 0.7W power consumption

9700

- ± 4 ppb stability -40°C to 65°C
- -140 dBc/Hz at 10 Hz offset

9800

- Output frequencies to 125 MHz
- ± 25 ppb stability -40°C to 65°C

9500

- STS for $\tau=1$ to 100 s $< 3\text{E}-13$
- ± 0.3 ppb stability -24°C to 60°C

SA.45s Space CSAC

- 120 mW power consumption
- ± 0.5 ppb stability -10°C to 70°C

Model	Type	Frequency Range (MHz)	Operating Temperature Range ($^{\circ}\text{C}$)	Temperature Stability (ppb)	Output Logic	Phase Noise (typical)			Radiation (TID) (krad)	Power (W)	Footprint (mm)
						10 Hz	100 kHz	carrier			
						dBc/Hz	dBc/Hz	MHz			
EX-219	EMXO	10 to 120	-40 to $+85$	100	CMOS, Sine	-120	-155	10	100	0.7	$26.1 \times 23.6 \times 9.7$
OX-249	OCXO	10 to 100	-40 to $+85$	100	CMOS, Sine, LVDS	-108	-163	10	300	1.5	$35.3 \times 20.3 \times 9.5$
9700	OCXO	4 to 60	-40 to $+65$	4	TTL, Sine, LVDS	-140	-160	10	100	1.3	$34.2 \times 34.2 \times 33.2$
9800	OCXO	40 to 125	-20 to $+70$	25	Sine	-100	-160	50	100	1.3	$34.2 \times 34.2 \times 33.2$
9500	OCXO	4 to 100	-24 to $+60$	0.3	TTL or LVDS	-145	-160	5	100	2.9	$227 \times 98.3 \times 83.2$
SA.45s Space	CSAC	10	-10 to $+70$	0.5	CMOS	-70	-140	10	20	0.12	$40.6 \times 35.3 \times 11.4$

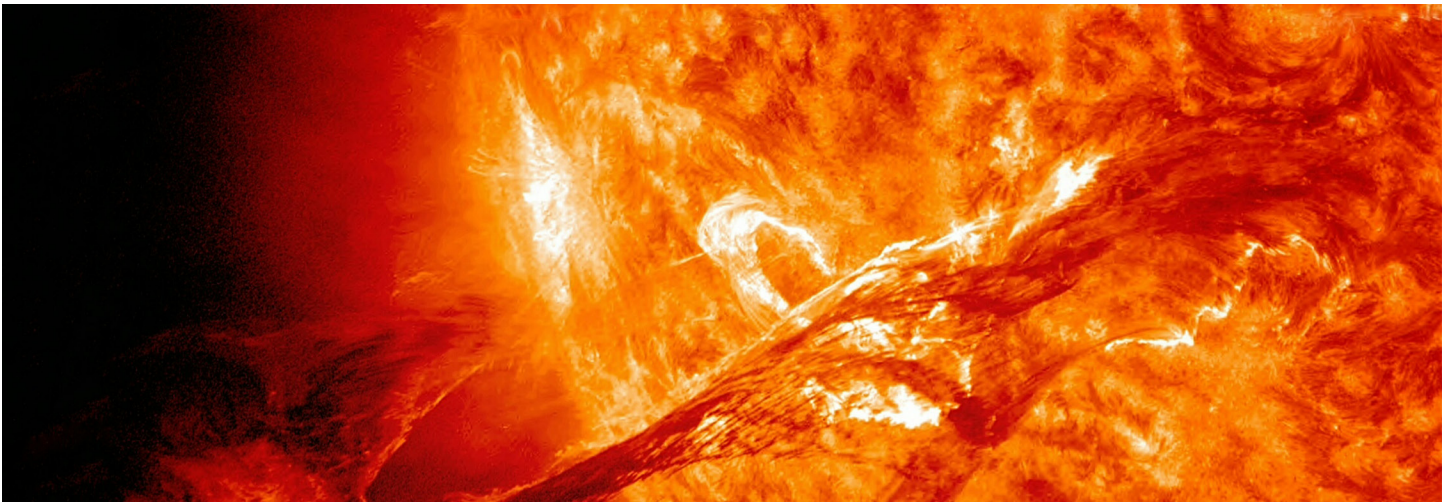

Radiation Summary

Deploying electronics into space greatly increases the radiation exposure to the components. High energy particles from solar flares and cosmic rays disrupt the lattice structures of the devices. These disruptions can lead to frequency shifts, temporary glitches, or complete device failure. For any space program, understanding the mission profile is critical to ensuring the correct radiation level devices are chosen. When required, Vectron Space Oscillators are either radiation hardened by component design, including swept quartz, or tested for specific tolerance levels. The table below summarizes the Total Ionizing Dose rating. For single event effects (SET, SEU, SEL, SEGR) please refer to the reference document or contact Microchip.

Total Ionizing Dose Summary (krad)				
20	50 (ELDRS)	100		300
Low Earth Orbit	Geosynchronous Orbit			Deep Space Exploration
CSAC	Clocks	Clocks	VCXO	Clocks
Sa.45 Space	DOC203810	OS-68338	DOC206218	DOC206379
	VCXO	DOC203679	DOC207753	DOC206903
	DOC204898	DOC204900	EMXO	DOC207975
	VCSO	MIL-PRF-55310	EX-219	VCSO
	DOC206906	TCXO	OCXO	DOC206559
		DOC200103	9700	OCXO
		DOC207139	9800	OX-249
			9500	



General Notes of Interest

Class S per MIL-PRF-55310

Microchip is one of only two companies approved for Class S oscillators per MIL-PRF-55310. We pride ourselves in having this unique approval. However, there are times when the offering under MIL-PRF-55310 does not fit your needs. For these occasions, Microchip has available specifications for each oscillator type which will completely specify an oscillator for a space environment without you having to produce their own SCD. Many of our best space customers have adopted this unique Microchip approach because it saves them much time and money. Our specifications are provided at no cost to you and allows for many choices or grades of oscillators through the part number building process. You can order engineering units without extensive testing all the way up to top level Class S or Class K screened parts and many levels in between. Contact our MIL/Space application engineers to discuss your needs and to get copies of our specifications.

Mounting Points on Crystal Blanks

The extreme shock and vibration levels experienced during the launch of all spacecraft is of special interest to all engineers. The most fragile component used in oscillators and filters is the quartz crystal. Many OEM's specifying crystal oscillators and filters for space use have adopted the policy of mandating either a 3- or 4-point mounting structure for all quartz crystals. Microchip uses the 4-point crystal mount for all space platforms except the Model 1118 which uses a 3-point crystal mount.

Lead Forming

Lead forming is available on some packages such as flatpacks. Tools for this purpose have previously been manufactured and the resultant formed lead dimensions are available by contacting your Microchip Applications Engineer. Note that no testing can be done after the leads are formed as this will change the critical dimensions achieved by the bending operation.



SMART | CONNECTED | SECURE

Microchip Technology Inc. | 2355 W. Chandler Blvd. | Chandler AZ, 85224-6199 | microchip.com